

Allocation Uncertainty: Tips, Tricks and Pitfalls

Phil Stockton, Accord Energy Solutions Ltd
Allan Wilson, Accord Energy Solutions Ltd

1 INTRODUCTION

Measurement uncertainties and their estimation have been the subject of much discussion and analysis. However allocation uncertainties have not been so well explored – specifically the way in which the uncertainties in measurements propagate through the allocation process.

The uncertainty of allocated quantities can be considered as a Field or partner's exposure to random gains (and losses) in the allocation results and should be understood in order to reach a fair and equitable allocation.

This paper describes methods of analytically calculating allocation uncertainties. It also highlights potential pitfalls and how to avoid them in typical calculations: for example, the uncertainty of a component mass flow, calculated as the product of total flow and mass component fraction, is not as straightforward as might at first be expected. This and other examples, which are presented as a series of case histories, are borne out of the authors' experiences in analysing uncertainties in a wide variety of systems.

Many of the pitfalls were revealed by comparing the results from the analytical approach with those generated using a stochastic Monte Carlo approach. The paper describes how a combination of the two approaches is perhaps the most effective in calculating allocation uncertainties¹. It goes on to describe how the analytical approach provides a deeper understanding of the uncertainties when comparing different allocation schemes. This is developed to generate a more general uncertainty map or landscape on which Pro Rata, By Difference and Uncertainty Based Allocation methods are compared.

In Section 2, the basic analytical and Monte Carlo methods to calculate and combine uncertainties are described and some useful results presented.

In Section 3, several applications of the equations are applied to real world examples in the form of case studies. These highlight potential pitfalls and the requirement for a clear understanding of concepts such as:

- independence of variables
- covariance
- difference between relative and absolute uncertainty.

These examples also serve to illustrate the benefits of the authors' preferred approach of attacking the calculations using both analytical and Monte Carlo techniques.

Section 4, commences with a discussion which compares the Monte Carlo and analytical approaches. It goes on to present equations for the uncertainties associated with three methods of allocation: By Difference, Pro Rata (or proportional) and Uncertainty Based Allocation (UBA). These equations are presented in concise and useful forms. The power of the analytical method is then exploited to explore the landscape of the uncertainty for the three aforementioned methods of allocation to afford a deeper understanding of their comparative uncertainties. The results of the analysis are presented in simplified equations that trace the boundaries where one type of allocation has an equal uncertainty to another

¹ It is acknowledged that there are other methods of calculating and combining uncertainties, for example quadrature. However, this paper is borne out of the authors' particular experiences and it is the combined use of analytical and Monte Carlo approaches that they have found to be beneficial.

and allows the ready determination of which is the better method of allocation from an uncertainty viewpoint. Many of the results are also illustrated graphically.

Section 5 provides a series of guidelines, borne out of the authors' experience, for the calculation of allocation uncertainty.

Equations are presented throughout the main body of text, generally without derivation. This is to aid readability of the paper: where considered appropriate the derivations are presented in the Appendix in Section 8.

2 CALCULATION OF UNCERTANTIES

2.1 Guides and Standards

In 1993, the Guide to the Expression of Uncertainty in Measurement [1], or GUM as it is commonly referred to, was published by the International Organization for Standardization (ISO) in association with six other international organizations². The foreword to the GUM states that "In 1978, recognizing the lack of international consensus on the expression of uncertainty in measurement, the world's highest authority in metrology, the Comite International des Poids et Mesures (CIPM), requested the Bureau International des Poids et Mesures (BIPM), to address the problem in conjunction with the national standards laboratories and to make a recommendation." This resulted in the publication of the ISO Guide, which has been accepted as the de facto international standard for the expression of uncertainty in measurement.

The approach in the GUM is based on the Taylor Series Method (TSM) to model the propagation of uncertainties, and the use of the term "analytical" with reference to uncertainty calculations denotes this TSM method. This is to distinguish that propagation approach from the Monte Carlo Method (MCM), which is described in a Supplement to the GUM [2].

This perhaps rather laboured introduction is presented to show that the calculation of the propagation of uncertainties has been considered by several august organisations and the methods developed rigorously. The methods presented in the GUM are utilised extensively, not only in the metering industry, e.g. ISO 5168 [3], but throughout the world of science and engineering. For example, Monte Carlo methods are routinely used in the analysis of data generated by particle accelerators such as CERN's Large Hadron Collider which recently discovered a Higg's-like particle.

The purpose of this preamble is to illustrate that there are recognised, correct mathematical methods that can be used for the propagation of uncertainties. An exhaustive discussion of the various methods is presented in [4].

2.2 Analytical Uncertainties

The TSM is described in the GUM. The basic equation for the uncertainty in a result y , which is a function of a number (N) of input variables (x_i), is given by:

$$U_y = \sqrt{\sum_{i=1}^N U_{x_i}^2 \times \left(\frac{\partial y}{\partial x_i}\right)^2} \quad (1)$$

In fact this is the simplest form of the equation presented in the GUM. There are potentially additional terms which account for:

² Bureau International des Poids et Mesures (BIPM), International Electrotechnical Commission (IEC), International Federation of Clinical Chemistry (IFCC), International Union of Pure and Applied Chemistry (IUPAC),), International Union of Pure and Applied Physics (IUPAP), International Organization of Legal Metrology (OIML).

- higher order partial derivatives which are required if the equation is highly non-linear – these higher order terms can usually be ignored
- covariance terms to account for the case when the input quantities x_i are correlated – these, as will be seen, cannot always be ignored.

The equation above is in terms of **absolute** uncertainties U_y and U_{x_i} ; the **relative** uncertainty of y is calculated by dividing U_y by y to obtain ϵ_y . Often the relative uncertainty in an input variable x_i will be given and the absolute uncertainty is obtained by multiplying ϵ_{x_i} by x to obtain U_{x_i} .

When talking of measurements, generally these are assumed to be normally distributed, with 95% of measurements lying within ± 2 standard deviations of the average value as illustrated in Figure 1:

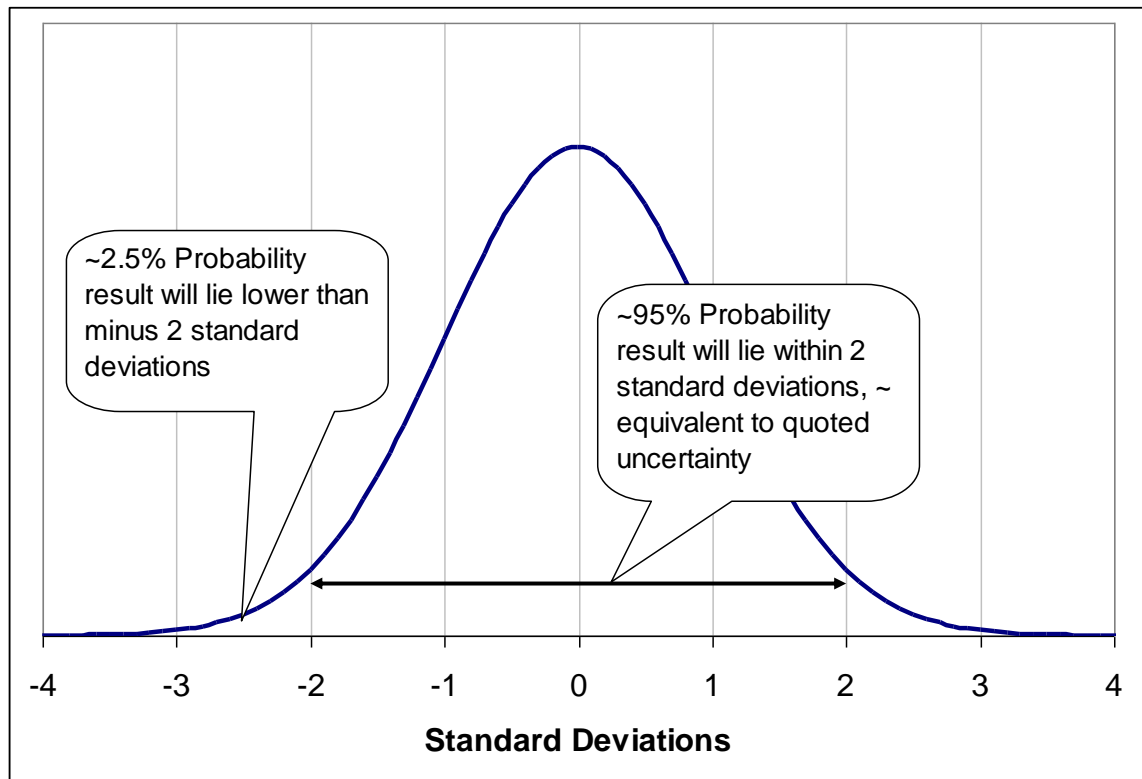

Figure 1 – Normal Distribution Probability Distribution, Standard Deviation and Uncertainty

The partial derivative term in Equation (1) is also referred to as the sensitivity coefficient. The sensitivity coefficient describes the impact that the individual input variable x_i has on the result y .

A useful result can be obtained for equations that involve only multiples and quotients of variables. In this instance the relative uncertainty of the result (y) is the root sum square of the input variables' (x_i) relative uncertainties. So for example, if:

$$y = x_1 * x_2 \quad (2)$$

then the **relative** uncertainty in y is simply given by:

$$\epsilon_y = \sqrt{\epsilon_{x_1}^2 + \epsilon_{x_2}^2} \quad (3)$$

This specific form of the equation is derived from Equation (1) (see Section 8.1 of Appendix) and in fact works for any equations of the form:

$$y = k * x_1^a * x_2^b * x_3^c \dots \quad (4)$$

for which the relative uncertainty in y is calculated from:

$$\varepsilon y = \sqrt{a^2 * \varepsilon x_1^2 + b^2 * \varepsilon x_2^2 + c^2 * \varepsilon x_3^2 + \dots} \quad (5)$$

Here the powers a, b, c, etc can be negative representing variables in the denominator. So for example the molar density of a perfect gas is given by:

$$\rho = \frac{P}{RT} \quad (6)$$

And its relative uncertainty is calculated from:

$$\varepsilon \rho = \sqrt{1^2 * \varepsilon P^2 + (-1)^2 * \varepsilon T^2} \quad (7)$$

(This assumes the uncertainty in the gas constant R is negligible).

Or for the volume of a cylinder:

$$V = \frac{\pi D^2}{4} \times L \quad (8)$$

$$\varepsilon V = \sqrt{2^2 \times \varepsilon D^2 + 1^2 \times \varepsilon L^2} \quad (9)$$

It should be noted that the constant, π , does not figure in the relative uncertainty equation and that the sensitivity coefficient for the diameter D, is 4 times that of the length L, because D is squared in the volume equation.

Though this specific form of the uncertainty equations is useful it can ONLY be used for equations of the form presented in Equation (4) and should NOT be used for other equation forms: for example the equation for allocating By Difference is represented by:

$$y = x_1 - x_2 \quad (10)$$

The **relative** uncertainty in y, in this case is:

$$\varepsilon_y = \frac{\sqrt{(1)^2 * x_1^2 * \varepsilon_{x_1}^2 + (-1)^2 * x_2^2 * \varepsilon_{x_2}^2}}{y} \quad (11)$$

The analytical uncertainties for By Difference and various other allocation methods are presented in Section 4.

2.3 Monte Carlo Uncertainties

The Monte Carlo Method is a powerful tool for performing uncertainty analysis. The basic methodology is described below, but detailed descriptions can be found in [2] and [4]. Using the volume of the cylinder equation as an example:

- The true values of D and L are assumed.
- The estimates of the random uncertainty for D and L are obtained.
- Appropriate probability distribution functions are assumed to describe the variation of the random uncertainties – usually these will be Gaussian (normal).

- A random number generator is used to produce a value of the random error independently for each input variable which is consistent with the random uncertainty and probability distribution functions.
- These random errors are applied to the true values to obtain “measured values” for D and L.
- Using the “measured” D and L, the volume V is calculated.

This process corresponds to running the simulation once. The process is repeated M (where M may be 1,000 or 100,000 or ..., etc. depending on the problem) times to obtain a distribution of the output result V. The standard deviation and hence uncertainty can then be obtained for V from the distribution of the simulation results generated. The results of a typical Monte Carlo simulation are presented in Figure 2.

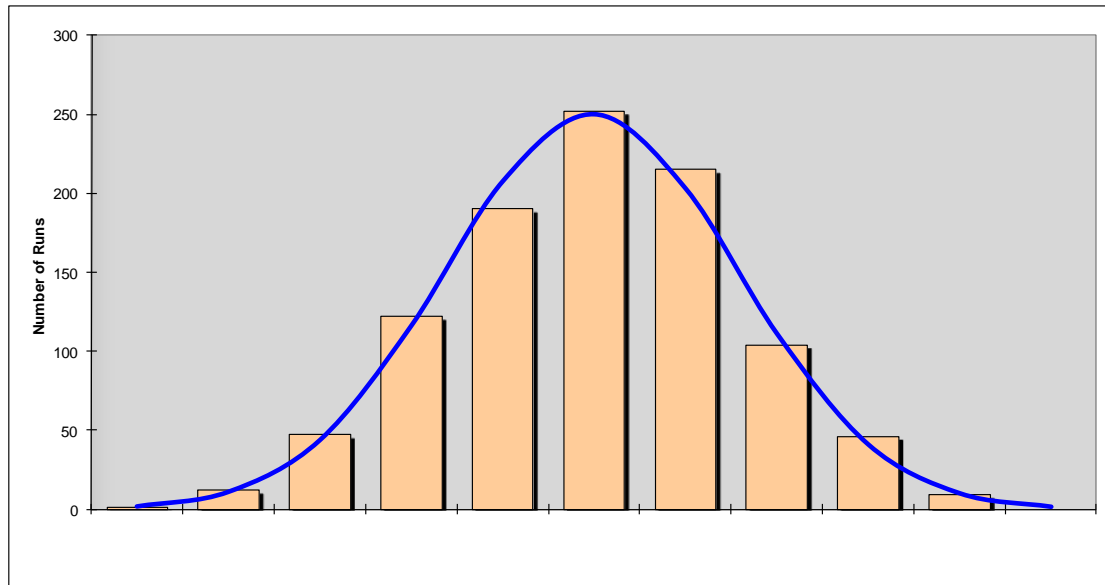

Figure 2 – Monte Carlo Simulation Results with Normal Distribution Overlaid

3 CASE STUDIES

3.1 Introduction

The following sections describe a series of case studies associated with the calculation of uncertainties in allocation systems. These are based on real world problems but the systems and data have been anonymised – though the data presented are representative of the real systems.

These case studies are intended to describe the correct application of the propagation of error equations and highlight areas where pitfalls can be encountered. These studies also illustrate the power of the complementary use of analytical (TSM) and Monte Carlo (MCM) methods to cross check against each other.

3.2 Offshore Gas Condensate System

This example involves a mass allocation to Field Alpha based on wet gas flow measurements and Field Bravo is allocated By Difference.

The basic process is illustrated in Figure 3:

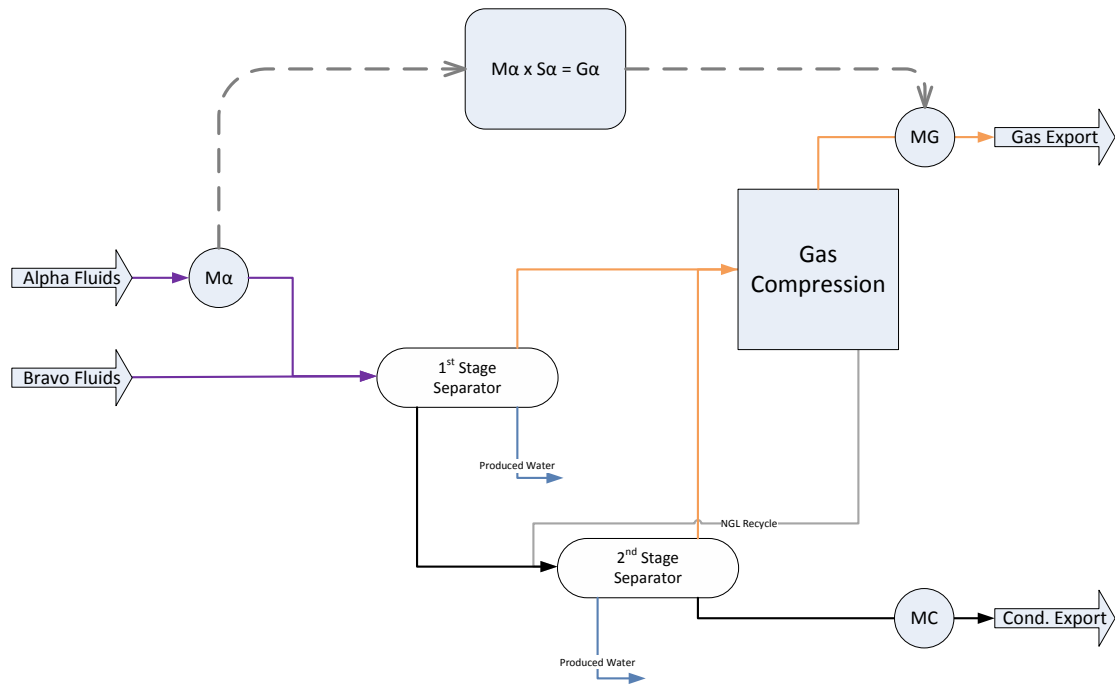

Figure 3 – Offshore Gas Condensate Process Schematic

Field Alpha's allocated export gas (G_{α}) is calculated as the product of its measured inlet flow (M_{α}) multiplied by a process factor (S_{α}) to account for liquid drop out in the topsides process:

$$G_{\alpha} = M_{\alpha} * S_{\alpha} \quad (12)$$

Since Alpha's allocated gas is just the product of two terms, Equation (3) can be used to calculate its relative uncertainty as the square root of the sum of the squares of the **relative** uncertainties in Alpha's metered inlet and process factor:

$$\varepsilon_{G_{\alpha}} = \sqrt{\varepsilon_{M_{\alpha}}^2 + \varepsilon_{S_{\alpha}}^2} \quad (13)$$

Field Bravo's gas (G_{β}) is allocated By Difference between the measured total export gas (MG) and Alpha's allocated gas (G_{α}):

$$G_{\beta} = MG - G_{\alpha} \quad (14)$$

Bravo's allocated gas is just the difference between two terms and Equation (11) can be used to calculate its relative uncertainty:

$$\varepsilon_{G_{\beta}} = \frac{\sqrt{1^2 * MG^2 * \varepsilon_{MG}^2 + (-1)^2 * G_{\alpha}^2 * \varepsilon_{G_{\alpha}}^2}}{G_{\beta}} \quad (15)$$

The condensate was allocated to Alpha as metered inlet minus its allocated gas mass.

$$C_{\alpha} = M_{\alpha} - G_{\alpha} \quad (16)$$

And Bravo's condensate as the difference between the total measured condensate and that allocated to Alpha:

$$C_{\beta} = MC - C_{\alpha} \quad (17)$$

At first sight it may appear to be appropriate to calculate the uncertainty in Alpha's allocated condensate using Equation (11), with sensitivity coefficients of 1 and -1 respectively for $M\alpha$ and $G\alpha$:

$$\varepsilon_{C\alpha} = \frac{\sqrt{(\varepsilon_{M\alpha} * M\alpha)^2 * 1^2 + (\varepsilon_{G\alpha} * G\alpha)^2 * (-1)^2}}{C\alpha} \quad (18)$$

Bravo's condensate uncertainty is calculated in analogous fashion from:

$$\varepsilon_{C\beta} = \frac{\sqrt{(\varepsilon_{MC} * MC)^2 * 1^2 + (\varepsilon_{C\alpha} * C\alpha)^2 * (-1)^2}}{C\beta} \quad (19)$$

Table 1 presents the results of the above analytical uncertainty calculations based on representative measured flows, process factors and their associated uncertainties:

Table 1 – Offshore Gas Condensate Allocation System Analytical Uncertainties

			Alpha	Bravo	Gas Export	Condy Export
Inlet Flow	M	tonnes/d	1,000			
Process Factor	S		0.9			
Export Flow	M	tonnes/d			2,000	500
Allocated Gas	G	tonnes/d	900	1,100		
Allocated Condy	C	tonnes/d	100	400		
Flow Uncert	ε	Rel %	5.0%		1.0%	1.0%
Process Factor Uncert	εS	Rel %	5.0%			
Allocated Gas Uncert	εG	Rel %	7.1%	6.1%		
Allocated Condy Uncert	εC	Rel %	80.9%	20.3%		

The condensate allocation uncertainties appear high. The calculations were checked using the same input data in a Monte Carlo simulation and the results are presented in Table 2:

Table 2 – Offshore Gas Condensate Allocation System Monte Carlo Uncertainties

			Alpha	Bravo
Allocated Gas Uncert	εG	Rel %	7.0%	6.0%
Allocated Condy Uncert	εC	Rel %	45.1%	11.4%

There is good agreement with the analytical gas allocation uncertainties but the Monte Carlo analysis predicts the condensate uncertainties are roughly half the values determined above in the analytical treatment. In fact the calculation of the analytical uncertainty for the Alpha condensate is incorrect and this highlights a pitfall that must be avoided when calculating uncertainties.

As discussed above (in Section 2.2), using Equation (1) to combine the uncertainties in the various quantities requires that each input variable in the equation is independent. If they aren't then the covariance terms need to be accounted for. The equation for Alpha's allocated condensate is just the difference between its metered inlet ($M\alpha$) and its allocated gas ($G\alpha$) – BUT these two terms are not independent since the allocated gas was calculated based on the metered inlet in Equation (16). In order to calculate Alpha's condensate uncertainty

correctly the equation must be expressed in terms of input variables that are independent of one another:

$$C_{\alpha} = M_{\alpha} - M_{\alpha} * S_{\alpha} = M_{\alpha}(1 - S_{\alpha}) \quad (20)$$

Now calculating the sensitivity coefficients for C_{α} in terms of M_{α} and S_{α} :

$$\frac{\partial C_{\alpha}}{\partial M_{\alpha}} = (1 - S_{\alpha}) \quad (21)$$

$$\frac{\partial C_{\alpha}}{\partial S_{\alpha}} = -M_{\alpha} \quad (22)$$

Now Alpha's allocated condensate relative uncertainty is given correctly by:

$$\varepsilon_{C_{\alpha}} = \frac{\sqrt{(\varepsilon_{M_{\alpha}} * M_{\alpha})^2 * (1 - S_{\alpha})^2 + (\varepsilon_{S_{\alpha}} * S_{\alpha})^2 * M_{\alpha}^2}}{C_{\alpha}} \quad (23)$$

Bravo's allocated condensate uncertainty can still be calculated according to Equation (19) as the total measured condensate (MC) and Alpha's allocated condensate (C_{α}) are independent of each other, though the uncertainty $\varepsilon_{C_{\alpha}}$ requires updating in accordance with (Equation 23). The revised condensate uncertainties are presented in Table 3:

Table 3 – Offshore Gas Condensate Allocation System Correct Analytical Uncertainties

			Alpha	Bravo
Allocated Gas Uncert	ε_G	Rel %	7.1%	6.1%
Allocated Cond Uncert	ε_C	Rel %	45.3%	11.4%

The corrected analytical and Monte Carlo uncertainties are now in excellent agreement.

PITFALL: Failure to recognise terms in an allocation equation that are dependent on one another particularly when utilising the results of one allocation step in a subsequent step.

TIP: When calculating the uncertainty, ensure that allocation equations are re-expressed in terms of independent terms, preferably inputs to the allocation system.

3.3 Mass Component Flows

Consider a stream for which mass flow and composition are measured. Table 4 presents figures for a representative gas stream containing 10 components for illustrative purposes. Also shown is the **relative** uncertainty in the gas mass fractions and total flow.

Table 4 – Gas Stream Flow and Composition

	Symbol	Units	Value	Rel Uncert
Flow	M	tonnes/d	1,000	1.0%
Composition				
N2	X _{N2}	mass %	1.0%	5.0%
CO2	X _{CO2}	mass %	3.0%	5.0%
C1	X _{C1}	mass %	73.0%	5.0%
C2	X _{C2}	mass %	12.0%	5.0%
C3	X _{C3}	mass %	7.0%	5.0%
iC4	X _{iC4}	mass %	2.0%	5.0%
nC4	X _{nC4}	mass %	1.0%	5.0%
iC5	X _{iC5}	mass %	0.5%	5.0%
nC5	X _{nC5}	mass %	0.4%	5.0%
C6+	X _{C6+}	mass %	0.1%	5.0%

To obtain the mass flow of any component, the flow and component mass fraction are simply multiplied together:

$$M_C = M_T * X_C \quad (24)$$

At first sight it might be expected that the uncertainty in M_C can be obtained using the equation for combining the uncertainties in products (as given by equation (3)). The results obtained in this way are presented in Table 5, along with the equivalent uncertainties determined by Monte Carlo simulation:

Table 5 – Gas Stream Flow and Composition

Component Mass	Symbol	Units	Value	Rel Uncert	
				Analytical	Monte Carlo
N2	M _{N2}	tonnes/d	10	5.1%	6.3%
CO2	M _{CO2}	tonnes/d	30	5.1%	6.2%
C1	M _{C1}	tonnes/d	730	5.1%	1.8%
C2	M _{C2}	tonnes/d	120	5.1%	5.8%
C3	M _{C3}	tonnes/d	70	5.1%	6.0%
iC4	M _{iC4}	tonnes/d	20	5.1%	6.3%
nC4	M _{nC4}	tonnes/d	10	5.1%	6.3%
iC5	M _{iC5}	tonnes/d	5	5.1%	6.3%
nC5	M _{nC5}	tonnes/d	4	5.1%	6.2%
C6+	M _{C6+}	tonnes/d	1	5.1%	6.3%

The analytically determined relative uncertainty for all the component mass flows is the same because the same uncertainty was assumed for all components in this example. The Monte Carlo approach produces quite different uncertainties for the mass component flows, generally being slightly higher for the majority but significantly lower for the main component, methane (C1).

Once again why does the Monte Carlo simulation generate a different uncertainty, for this seemingly simple, almost trivial, calculation? The answer is revealed when the mechanics of performing the Monte Carlo simulation are examined in more detail. Table 6 shows the calculation steps associated with a single iteration of the Monte Carlo simulation:

Table 6 – Gas Stream Flow and Composition

Flow	M	Units	True Value	Measured Value	Normalised	Mass Cpt Result
		tonnes/d	1,000	991		Mi
N2	X _{N2}	mass %	1.0%	0.96%	0.94%	9.332
CO2	X _{CO2}	mass %	3.0%	3.03%	2.99%	29.603
C1	X _{C1}	mass %	73.0%	74.10%	72.98%	723.022
C2	X _{C2}	mass %	12.0%	11.98%	11.80%	116.874
C3	X _{C3}	mass %	7.0%	7.43%	7.31%	72.462
iC4	X _{iC4}	mass %	2.0%	2.07%	2.04%	20.246
nC4	X _{nC4}	mass %	1.0%	0.95%	0.94%	9.287
iC5	X _{iC5}	mass %	0.5%	0.52%	0.51%	5.076
nC5	X _{nC5}	mass %	0.4%	0.40%	0.40%	3.934
C6+	X _{C6+}	mass %	0.1%	0.09%	0.09%	0.922
Total			100.00%	101.54%	100.00%	

The True Value column shows the original composition and flow. The Measured Value column shows the result of the random deviation applied to the original figures – in effect a single measurement - significantly the composition now does not perfectly sum to 100%. This is the key step, the composition is normalised to obtain the final values. The component mass flow is determined using the re-normalised component mass fractions. What this renormalisation step reveals is that a slight increase (or decrease) in one component has to be balanced by corresponding decreases (or increases) in other components so that the composition sums to 100%. The measured component mass fractions are not independent of each other but exhibit covariance and this must be accounted for in the analytical uncertainty calculations.

As mentioned in Section 2.2, Equation (1), and hence (3), should be modified to include extra terms to account for covariance. The GUM [1] presents the modified equation as:

$$U_y = \sqrt{\sum_{i=1}^N U_{x_i}^2 \left(\frac{\partial y}{\partial x_i} \right)^2 + 2 \sum_{i=1}^{N-1} \sum_{j=i+1}^N r_{i,j} U_{x_i} U_{x_j} \left(\frac{\partial y}{\partial x_i} \right) \left(\frac{\partial y}{\partial x_j} \right)} \quad (25)$$

Covariance terms

The additional covariance terms account for the inter-dependence of the input variables x_i and x_j , and these terms comprise:

- the product of the uncertainties
- the product of the sensitivity coefficients
- the correlation coefficient $r_{i,j}$ which reflects the degree to which the values of x_i and x_j correlate with each other. A value of one indicates complete correlation; zero reflects no correlation, i.e independence; a value of less than one indicates that one variable decreases as the other increases.

The result of the product of the covariance terms can be negative as well as positive, meaning that it can reduce the uncertainty in y as well as increase it as was observed with the Monte Carlo uncertainties.

An obstacle arises here in that, for all but the simplest cases, it is difficult to obtain the correlation coefficient $r_{i,j}$.

However, in this example the uncertainty can be calculated by re-expressing Equation (24) slightly differently in a form that naturally accounts for the inter-dependence of the component mass fractions, for example for component N2 (nitrogen):

$$M_{N_2} = M_T \times \left(\frac{X_{N_2}}{\sum_C X_C} \right) \quad (26)$$

Though the denominator summation term is equal to one its inclusion in calculating the uncertainty means that uncertainties and sensitivity coefficients for all components are now included in the uncertainty of the mass component flow. So for example the uncertainty of component N2 is given by:

$$\varepsilon_{M_{N_2}} = \frac{\sqrt{(\varepsilon_{M_T} * M_T * X_{N_2})^2 + \sum_{C \neq N_2} (\varepsilon_C * X_C * M_{N_2})^2 + (\varepsilon_{N_2} * X_{N_2} * M_T * (1 - X_{N_2}))^2}}{M_{N_2}} \quad (27)$$

The results, which now agree with the Monte Carlo figures, are presented in Table 7:

Table 7 – Mass Component Flow Corrected Uncertainties

Component Mass	Symbol	Units	Value	Rel Uncert	
				Analytical	Monte Carlo
N2	M_{N_2}	tonnes/d	10	6.27%	6.26%
CO2	M_{CO_2}	tonnes/d	30	6.19%	6.18%
C1	M_{C_1}	tonnes/d	730	1.83%	1.85%
C2	M_{C_2}	tonnes/d	120	5.82%	5.81%
C3	M_{C_3}	tonnes/d	70	6.03%	6.05%
iC4	M_{iC_4}	tonnes/d	20	6.23%	6.33%
nC4	M_{nC_4}	tonnes/d	10	6.27%	6.32%
iC5	M_{iC_5}	tonnes/d	5	6.29%	6.25%
nC5	M_{nC_5}	tonnes/d	4	6.30%	6.21%
C6+	M_{C_6+}	tonnes/d	1	6.31%	6.32%

PITFALL: Failure to recognise terms in an allocation equation that are dependent on one another. This dependence may not be explicit in the allocation equations themselves, for example the requirement for a composition to sum to 100%.

TIP: Ensure that implicit constraints in the allocation system equations are accounted for when calculating uncertainty. For example the constraint that requires a composition to sum to 100% resulting in covariance between the component mass (or molar) fractions.

TRICK: When calculating partial derivatives for sensitivity coefficients, re-express mass (or molar) fractions as the component fraction divided by the sum of the component

fractions. This will mean that all components will feature in the uncertainty calculation for each individual component and will account for their covariances.

3.4 Multiphase Flow Meter Oil and Water Flows

The type of Multiphase flow meter (MPFM) that is being discussed in this section is the type that infers the ratio of oil and water (and gas) by firing electromagnetic beams across the flow.

Manufacturer's of such MPFMs generally present the uncertainty of the liquid phases in terms of an overall liquid flow **relative** uncertainty and an **absolute** water liquid ratio uncertainty. Some representative values are presented in Table 8:

Table 8 – Illustrative MPFM Uncertainties

Liquid flow	Relative uncertainty	5%
WLR	Absolute uncertainty	3%

These are typical but deliberately not any particular manufacturer's data. The important points to note are that:

- the uncertainty in the individual oil and water liquid phases are not quoted
- the liquid flow uncertainty is a **relative** value
- the WLR uncertainty is an **absolute** value.

The oil and water flows are calculated respectively from:

$$M_{Oil} = M_{Liq} * (1 - WLR) \quad (28)$$

And,

$$M_{Wat} = M_{Liq} * WLR \quad (29)$$

The **relative** uncertainty in the oil flow is given by:

$$\varepsilon_{M_{Oil}} = \frac{\sqrt{(\varepsilon_{Liq} * (1 - WLR))^2 + (e_{WLR})^2}}{(1 - WLR)} \quad (30)$$

The relative uncertainty of the oil is not a function of the total liquid flow but dependent on the WLR. Note also the use of the **relative** liquid flow uncertainty and **absolute** WLR uncertainty in the above equation.

What is also apparent on inspection of the above equation is that the relative uncertainty in the oil becomes very large as the WLR approaches 1. At first sight this may appear alarming but evaluation of the analogous absolute uncertainty as given by:

$$e_{M_{Oil}} = M_{Liq} \sqrt{(\varepsilon_{Liq} * (1 - WLR))^2 + (e_{WLR})^2} \quad (31)$$

reveals that the absolute uncertainty tends to some finite value.

Based upon a total liquid flow of 1,000 Sm³/d and using the uncertainties in Table 7, the relative and absolute uncertainties of the oil flow are plotted as functions of WLR from 0 to 1 in Figure 4:

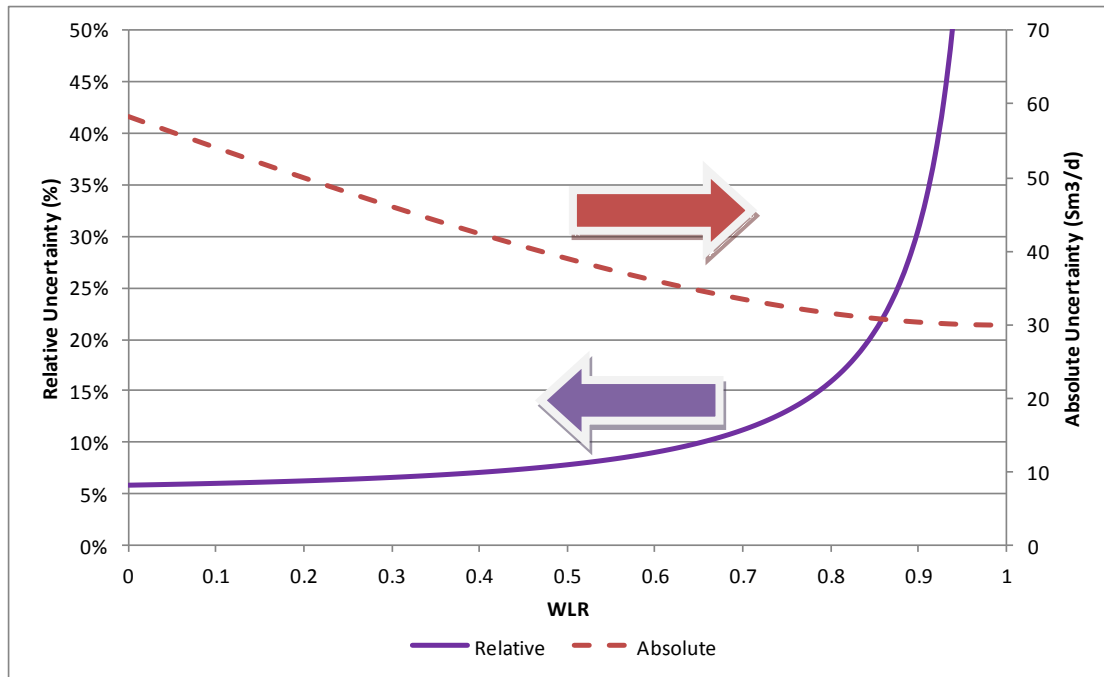

Figure 4 – Uncertainty in MPFM Oil Flow as a Function of WLR

The relative uncertainty rises asymptotically as the WLR approaches one. However, due to the falling oil flow the absolute uncertainty in fact falls. The relative uncertainty rises because the absolute uncertainty value represents a larger fraction of the oil flow.

In fact the exposure, as represented by the uncertainty, in the oil flow actually falls as the WLR rises. This illustrates the requirement to consider both relative and calculated uncertainties in allocated or measured quantities.

Similar trends are observed with the water uncertainty at low WLRs; the relative uncertainty is given by:

$$\varepsilon_{M_{\text{Wat}}} = \frac{\sqrt{(\varepsilon_{\text{Liq}} * \text{WLR})^2 + (e_{\text{WLR}})^2}}{\text{WLR}} \quad (32)$$

Note that the though the water flow is the product of M_{Liq} and WLR, Equation (5) is not applicable here, as the uncertainty in the WLR, e_{WLR} , is an absolute value.

The absolute uncertainty is given by:

$$e_{M_{\text{Wat}}} = M_{\text{Liq}} \sqrt{(\varepsilon_{\text{Liq}} \times \text{WLR})^2 + (e_{\text{WLR}})^2} \quad (33)$$

The analogous relative and absolute uncertainties of the water flow are plotted in Figure 5:

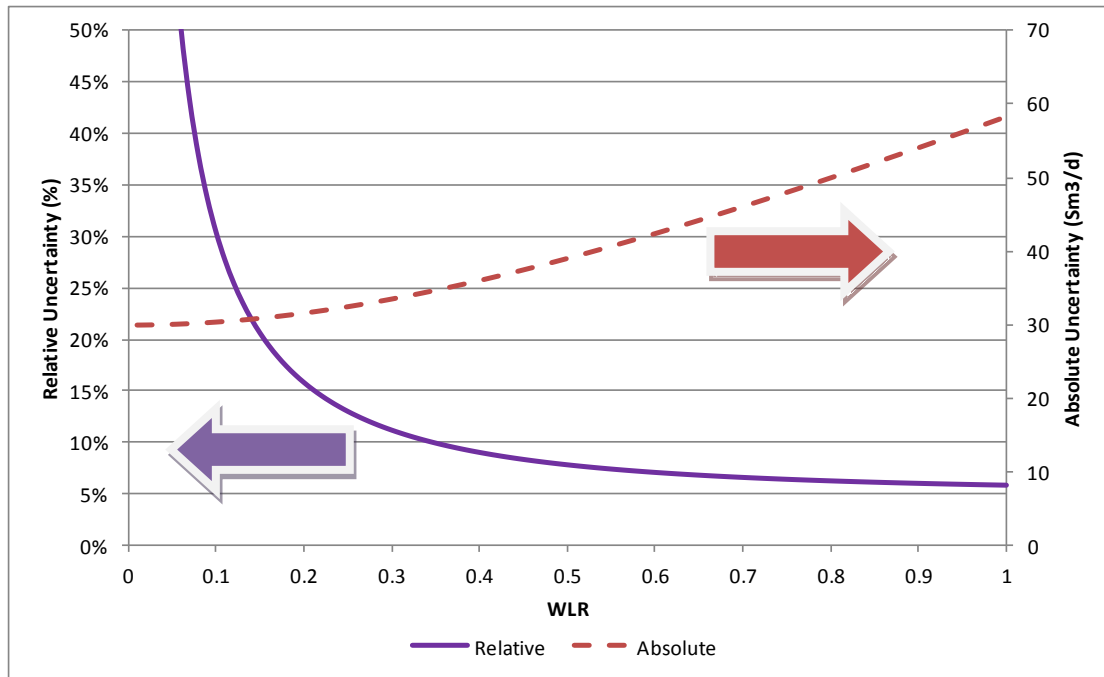

Figure 5 – Uncertainty in MPFM Water Flow as a Function of WLR

The high water relative uncertainty observed at low WLR occurs when oil dominates the liquid phase.

This case study illustrates methods of combining absolute and relative uncertainties and the requirement to consider both relative and absolute uncertainties in the calculated quantities to understand the significance of the exposure in the calculated result.

PITFALL: Assuming that a constant relative uncertainty applies for the individual oil and water phase flow rates for an MPFM across the range of water cut.

TIP: Ensure that the individual oil and water flow uncertainties are calculated based on the liquid flow and WLR uncertainties - the uncertainties will vary with water cut.

PITFALL: Assuming that a high relative uncertainty in oil or water phase flow rates is necessarily a problem.

TIP: Determine both absolute and relative uncertainties for the oil and water flow rates as a high relative uncertainty in flow may be a small absolute quantity.

4 ALLOCATION APPROACH ANALYSES

4.1 Analytical versus Monte Carlo?

At this point the question arises, why should the analytical uncertainty be calculated at all when the Monte Carlo approach seems to provide the correct answer whilst naturally accounting for covariances, etc?

Each Monte Carlo simulation provides a only snap shot of the uncertainty for one particular set of data, i.e. one set of flows, uncertainties, etc. With each simulation run consisting of

many thousands (or even millions) of iterations, the time taken to build up a picture over a range of flows in an allocation system may be significant³.

The analytical approach provides equations that describe the uncertainty over a range of flows almost effortlessly. This also allows various methods of allocation to be compared and gain a deeper understanding of the relative merits of each approach over the full range of flows.⁴

In the authors' experience the combined use of both approaches has proved to be advantageous in calculating and assessing the uncertainties associated with allocation methodologies.

In the following sections three main methods of allocation are compared from an uncertainty viewpoint. The simple example allocation system presented in Section 4.2 is used throughout the comparison exercise.

4.2 Pro Rata or Proportional Allocation

Consider a system where two fields are produced through a process and their commingled export production is measured. This is allocated to the fields in proportion to their individual measured or estimated production at the export point. The system is presented schematically in Figure 6:

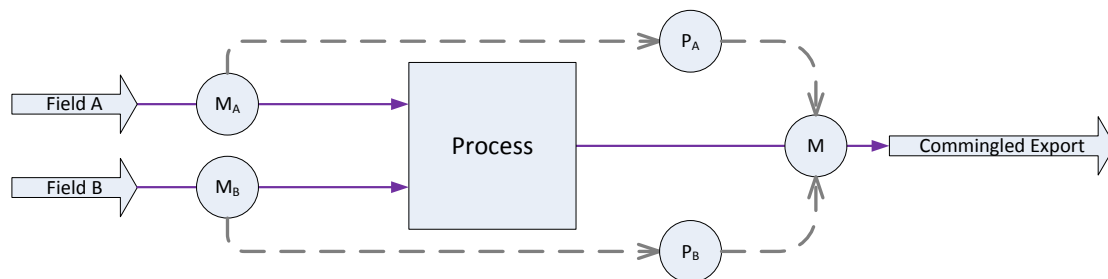

Figure 6 – Simple Process Schematic

The quantities allocated to A and B could be oil, gas, water, etc. The estimated production at the export point P_A and P_B may be equal to direct measurements of A and B as given by M_A and M_B , or based on M_A and M_B and some factor to account for processing. M_A and/or M_B may be continuous measurements or based on well tests.

However P_A and P_B are determined it is assumed that they provide an estimate of the flow from each Field at the measurement point and that their uncertainties are available or have been calculated appropriately. In the ensuing discussion, the uncertainty in these quantities will be referred to as their measurement uncertainties. Also the uncertainty in the commingled export flow measurement, M , is known.

Allocated quantities employing the proportional method are given by:

$$A_A = M * \left(\frac{P_A}{P_A + P_B} \right) \quad (34)$$

and,

3 For example to build the three dimensional surface plots presented in Figure 17 and Figure 18, each consisting of approaching 1000 data points, would take over 7 hours to generate on the authors' spreadsheet used to perform the Monte Carlo simulations – each simulation consisting of 10,000 iterations.

4 In complex systems, the equations may be such that Monte Carlo simulation is the only practicable approach for calculating uncertainties.

$$A_B = M * \left(\frac{P_B}{P_A + P_B} \right) \quad (35)$$

The relative uncertainties in the allocated quantities, A_A and A_B , have been calculated using analytical approach and are given by⁵:

$$\varepsilon_{A,A} = \sqrt{\varepsilon_M^2 + (1-x)^2 (\varepsilon_{P,A}^2 + \varepsilon_{P,B}^2)} \quad (36)$$

$$\varepsilon_{A,B} = \sqrt{\varepsilon_M^2 + x^2 (\varepsilon_{P,A}^2 + \varepsilon_{P,B}^2)} \quad (37)$$

The relative uncertainties are functions of the relative uncertainties in the input quantities and x , which is the fraction Field A comprises of the total flow:

$$x = \left(\frac{P_A}{P_A + P_B} \right) \quad (38)$$

$$(1-x) = \left(\frac{P_B}{P_A + P_B} \right) \quad (39)$$

Assuming some values of the uncertainties for illustrative purposes:

- Commingled measurement, $\varepsilon_M = 1\%$
- Field A measurement, $\varepsilon_{P,A} = 5\%$
- Field B measurement, $\varepsilon_{P,B} = 10\%$

Substituting these values into Equations (36) and (37), Field A and B's allocation uncertainty can be plotted as a function of x as shown in Figure 7:

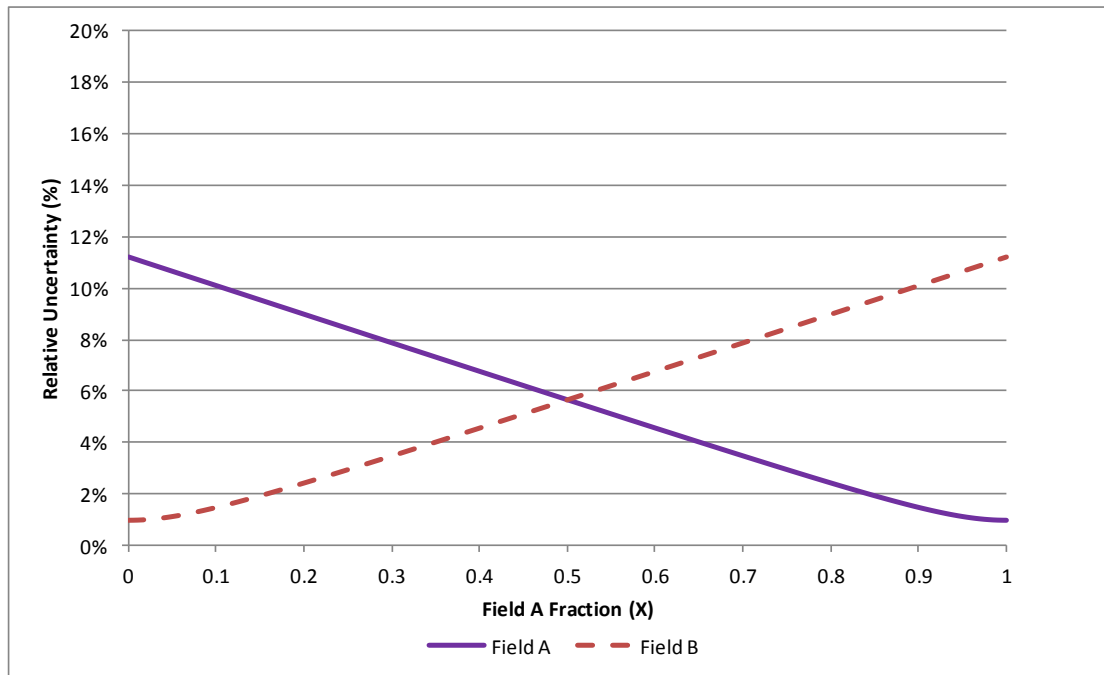

Figure 7 – Pro Rata Allocation Relative Uncertainty

⁵ The derivation is presented in Section 8.2 of the Appendix.

The Fields' allocation uncertainties are mirror images of one another as x increases from zero to one. The relative allocation uncertainty for Field A decreases as it occupies a larger share of the flow (increasing x) to a minimum value of 1% - this is determined by the export measurement uncertainty.

An important point to note is that though Field A has a better quality meter than Field B its allocation uncertainty is exactly the same as Field B's when they occupy the same fraction of the total flow. Reducing the uncertainty of any of the meters benefits the system as a whole but not any field specifically. Also the equations indicate that improving the uncertainty in the measurement with the largest uncertainty provides the largest benefit for the system as a whole.

The analogous plot for the absolute uncertainty is presented in Figure 8, based on a nominal combined flow of 1,000 – appropriate units are arbitrary and could be tonnes/d, kg/h, etc.

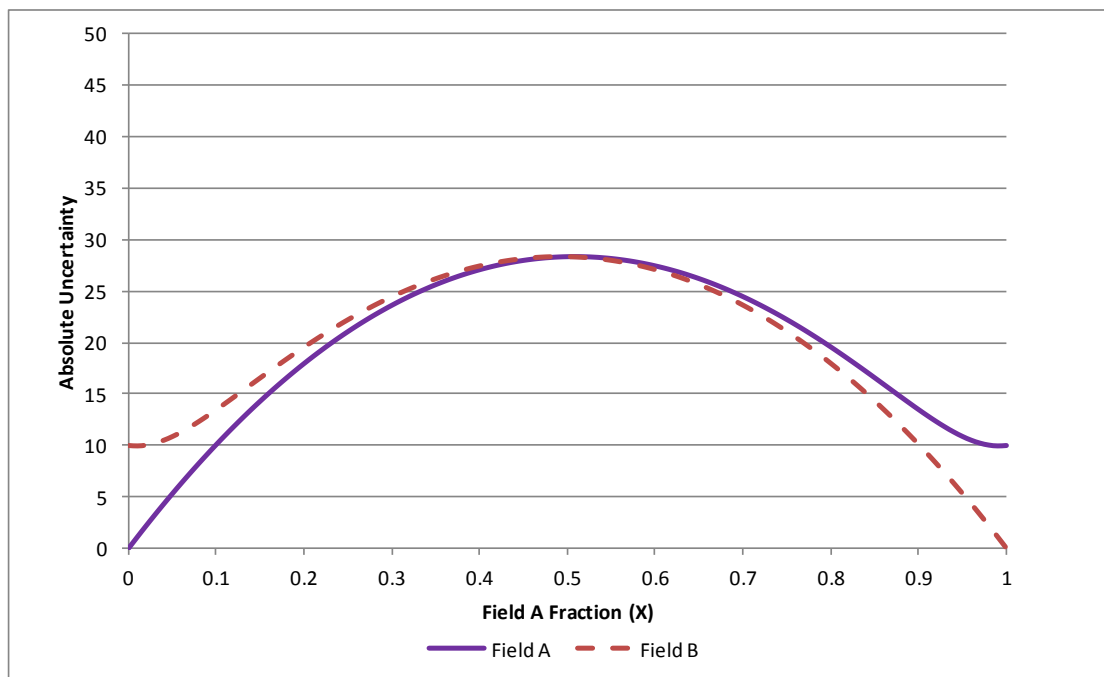

Figure 8 – Pro Rata Allocation Absolute Uncertainty

This shows that as x falls, the absolute uncertainty for Field A falls despite its relative uncertainty rising.

In order to provide more of an overview of the uncertainty a three dimensional plot of Field A's relative allocation uncertainty is presented in Figure 9:

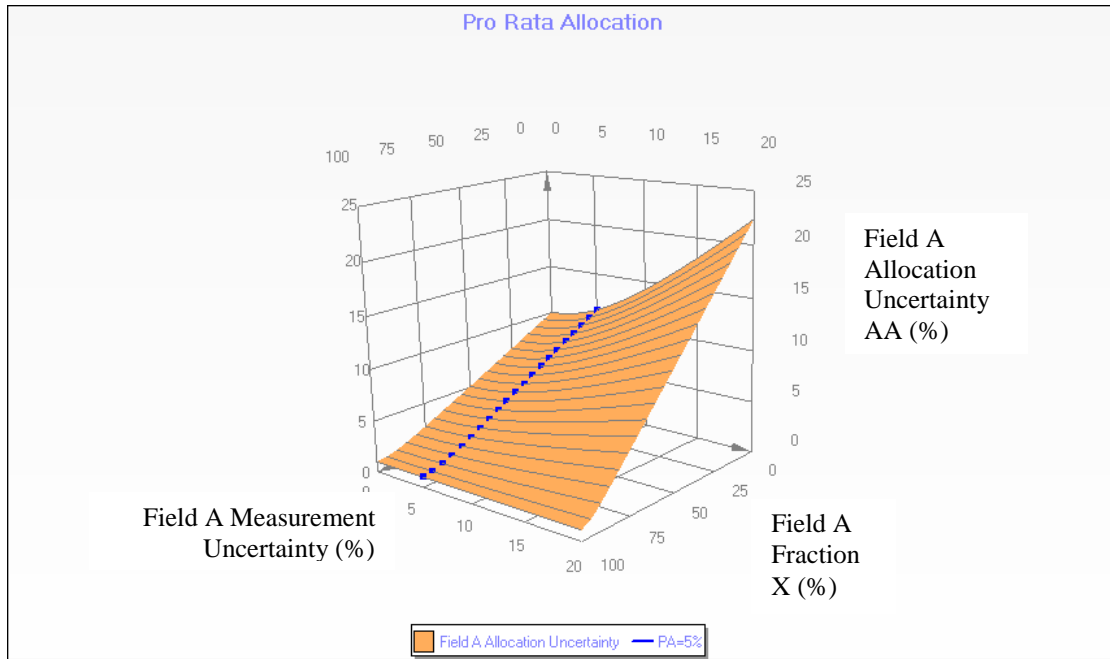

Figure 9 – Pro Rata Relative Allocation Uncertainty – Field A

The orange surface is Field A's relative allocation uncertainty plotted against the vertical axis (AA Uncertainty (%)). The fraction Field A comprises (X) is plotted on the horizontal axis right to left, and the uncertainty in Field A's production, $\varepsilon_{P,A}$, (from 0% to 20%) is plotted on the horizontal axis left to right.

Also shown by the black dots is the locus of Field A's allocation uncertainty when its measurement uncertainty is 5% corresponding with the plot in Figure 7.

4.3 By Difference Method

When employing the By Difference approach, the allocated quantities are given by:

$$A_A = P_A \quad (40)$$

for Field A and for Field B by difference,

$$A_B = M - P_A \quad (41)$$

(The system in this example is Field B allocated By Difference. Equally Field A could be allocated By Difference, but the analysis is basically the same).

The associated relative uncertainties are given by, for A:

$$\varepsilon_{A,A} = \varepsilon_{P,A} \quad (42)$$

And, similarly for A_B :

$$\varepsilon_{A,B} = \frac{\sqrt{\varepsilon_M^2 + X^2 \varepsilon_{P,A}^2}}{(1-x)} \quad (43)$$

Using the uncertainties presented in Section 4.2 the relative allocation and absolute uncertainties for both fields are presented in Figure 10 and Figure 11 respectively:

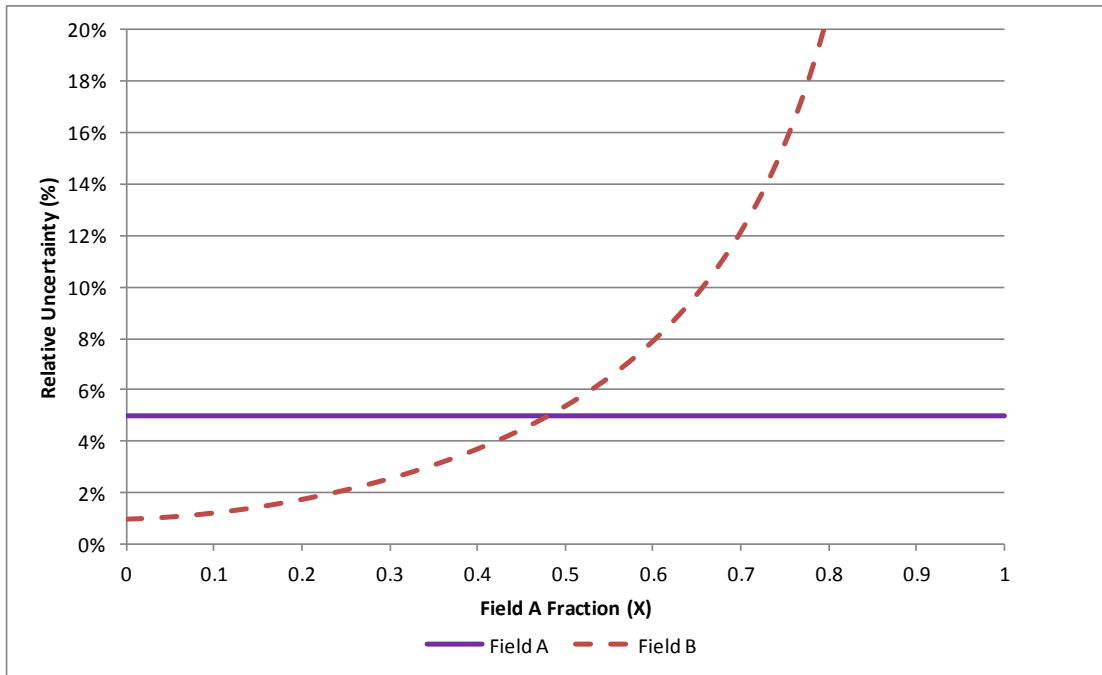

Figure 10 – By Difference Allocation Relative Uncertainty

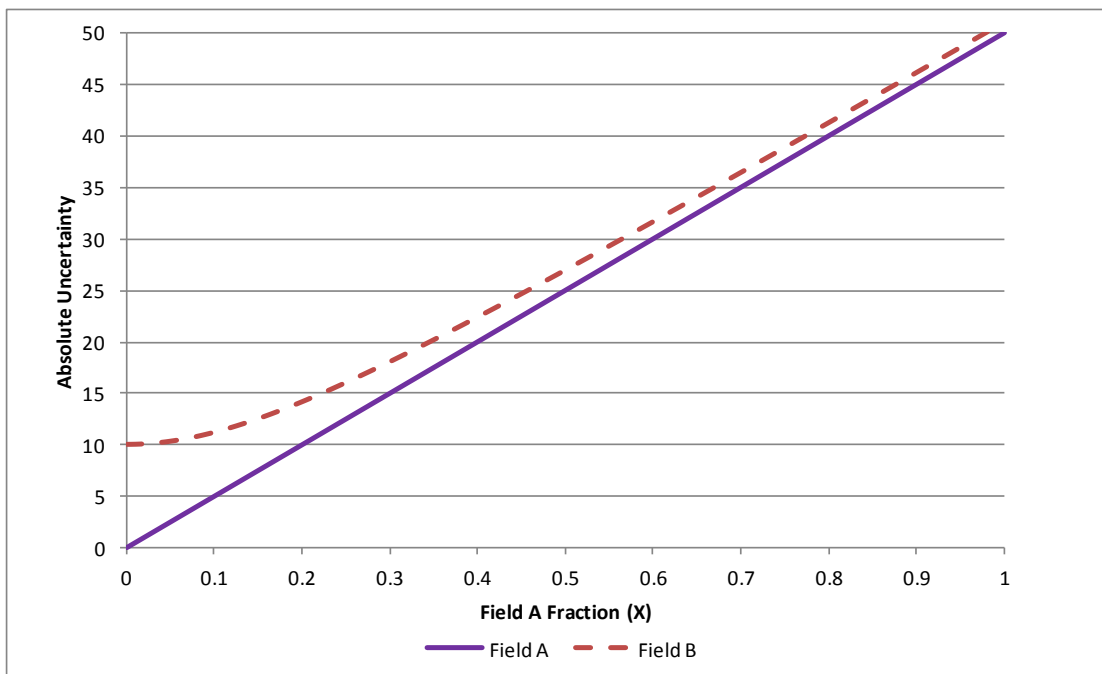

Figure 11 – By Difference Allocation Absolute Uncertainty

Perhaps the most salient feature of the above figures is the rise in Field B's allocation uncertainty as its flow relative to Field A declines. This occurs with its absolute uncertainty, which when combined with its reducing flow, results in an asymptotic rise in its relative

uncertainty. This illustrates the classic problem of allocating the minor producing field By Difference.

Conversely, also apparent when Field B is a high proportion of the flow, is that the allocation uncertainty for both Field A and B is lower than the Pro Rata approach. Using the analytical uncertainty equations the point at which this cross over occurs can be calculated. For Field A, this is given by:

$$\Psi_A = 1 - \frac{\sqrt{\left(\frac{\varepsilon_A}{\varepsilon_B}\right)^2 - \left(\frac{\varepsilon_M}{\varepsilon_B}\right)^2}}{\left(\frac{\varepsilon_A}{\varepsilon_B}\right)^2 + 1} \quad (44)$$

If x is less than ψ_A then By Difference allocation provides a lower uncertainty, if greater, then Pro Rata is better for Field A.

Interestingly the cross over point for Field B ψ_B is not the same and in fact requires the solution of the following cubic equation:

$$\left(\Psi_B^3 - 2\Psi_B^2\right)\left(\left(\frac{\varepsilon_A}{\varepsilon_B}\right)^2 + 1\right) + \Psi_B\left(\left(\frac{\varepsilon_M}{\varepsilon_B}\right)^2 + 1\right) - 2\left(\frac{\varepsilon_M}{\varepsilon_B}\right)^2 = 0 \quad (45)$$

This equation can be solved iteratively using direct substitution: assume an initial value for ψ'_B , say 0.5 and recalculate ψ_B from:

$$\Psi_B = \sqrt{\frac{\Psi_B'^3}{2} + \frac{\left(\Psi_B' \left(\left(\frac{\varepsilon_A}{\varepsilon_B}\right)^2 + 1\right) - 2\left(\left(\frac{\varepsilon_M}{\varepsilon_B}\right)^2 + 1\right)\right)}{2\left(\left(\frac{\varepsilon_A}{\varepsilon_B}\right)^2 + 1\right)}} \quad (46)$$

Then update ψ'_B to be equal to ψ_B as calculated by Equation (46) and iterate until convergence is achieved.

ψ_A and ψ_B are functions only of the uncertainties of the Export and Field A and B measurements. Using the uncertainties in the example above for the Export and Field B measurements, the operating regimes where Pro Rata and By Difference are preferred in terms of lowest uncertainty can be plotted as a function of Field A measurement uncertainty $\varepsilon_{P,A}$ as shown in Figure 12.

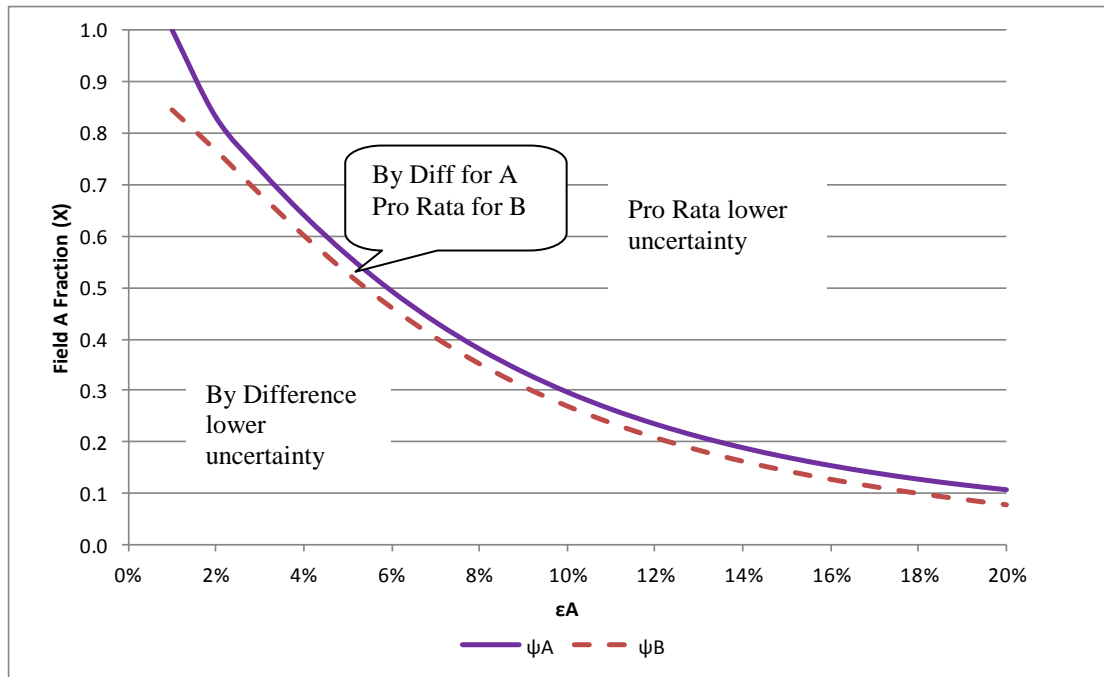

Figure 12 – Pro Rata versus By Difference Uncertainty Map

There is a small zone between the ψ_A and ψ_B lines where Pro Rata produces a lower uncertainty for Field B and By Difference is preferred for A. The size of this zone increases as the product meter uncertainty increases and disappears altogether when the product measurement uncertainty is zero.

4.4 Uncertainty Based Allocation Method

Uncertainty Based Allocation (UBA) utilises the uncertainties in the measurements in the allocation equations. The method calculates the imbalance (Δ) which is the difference between the export and sum of the Field measurements:

$$\Delta = M - P_A - P_B \quad (47)$$

and allocates this between the fields in proportion to the square of the absolute uncertainties in their measurements, for example for Field A:

$$\Delta_A = \Delta \left(\frac{e_A^2}{e_A^2 + e_B^2} \right) \quad (48)$$

This is then added to their measurement P_A .

By defining θ as:

$$\theta = \frac{e_A^2}{e_A^2 + e_B^2} = \frac{x^2 \varepsilon_A^2}{x^2 \varepsilon_A^2 + (1-x)^2 \varepsilon_B^2} \quad (49)$$

The allocated quantities employing the UBA method are given by:

$$A_A = P_A + \theta * \Delta \quad (50)$$

$$A_B = P_B + (1-\theta) * \Delta \quad (51)$$

The derivation of the Uncertainty Based Allocation approach has been discussed elsewhere [5], [6], [7] and is based on recognised mathematical techniques. The precise methodology discussed here is that developed in [7].

The method was developed to overcome the shortcomings in the Pro Rata and By Difference methods. Greater significance is placed on measurements from fields with better metering (lower uncertainty); accordingly their allocated quantities are closer to their measurements than less accurately metered fields. This mitigates the impact of any poorer quality measurements associated with the other field(s) in the system as observed in the Pro Rata approach. By incorporating all measurements it also avoids the high allocation uncertainties encountered with the By Difference method when the By Difference field is the minor producer in the system.

The relative uncertainty in Field A's allocation is given by:

$$\varepsilon_{A,A} = \frac{\sqrt{\theta^2 \varepsilon_M^2 + x^2 (1-\theta)^2 \varepsilon_{P,A}^2 + \theta^2 (1-x)^2 \varepsilon_{P,B}^2}}{x} \quad (52)$$

And similarly for Field B:

$$\varepsilon_{A,B} = \frac{\sqrt{(1-\theta)^2 (\varepsilon_M^2 + \varepsilon_{P,A}^2 x^2) + \theta^2 (1-x)^2 \varepsilon_{P,B}^2}}{(1-x)} \quad (53)$$

Using the uncertainties presented in Section 4.2 the relative allocation and absolute uncertainties for both fields are presented in Figure 10 and Figure 11 respectively:

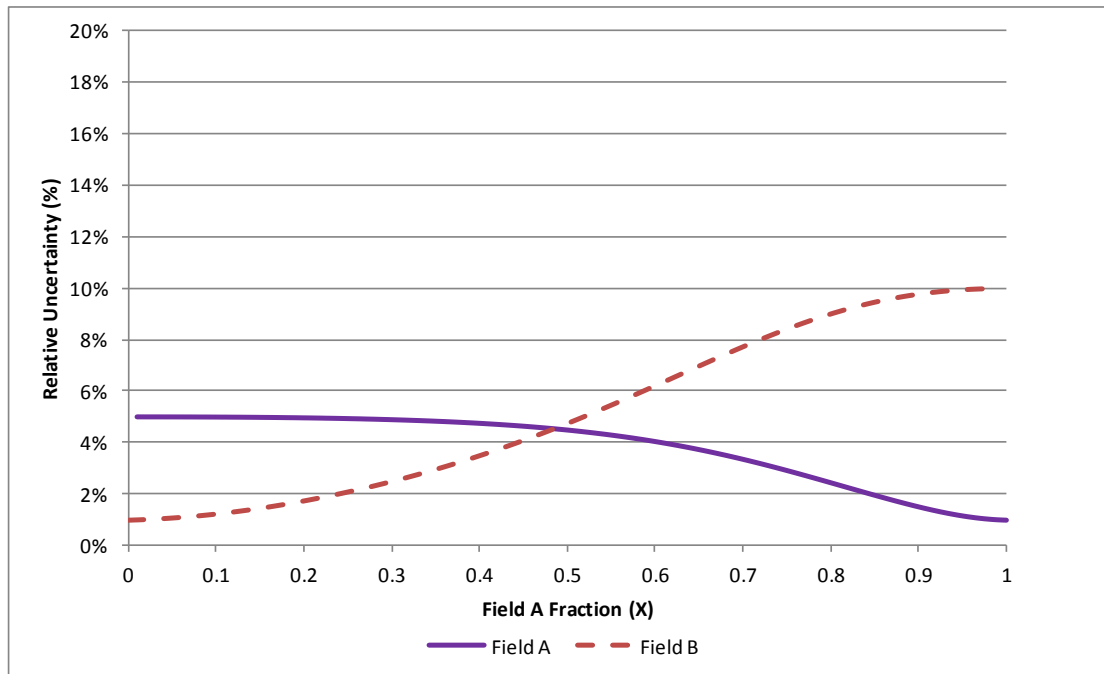

Figure 13 – UBA Relative Uncertainty

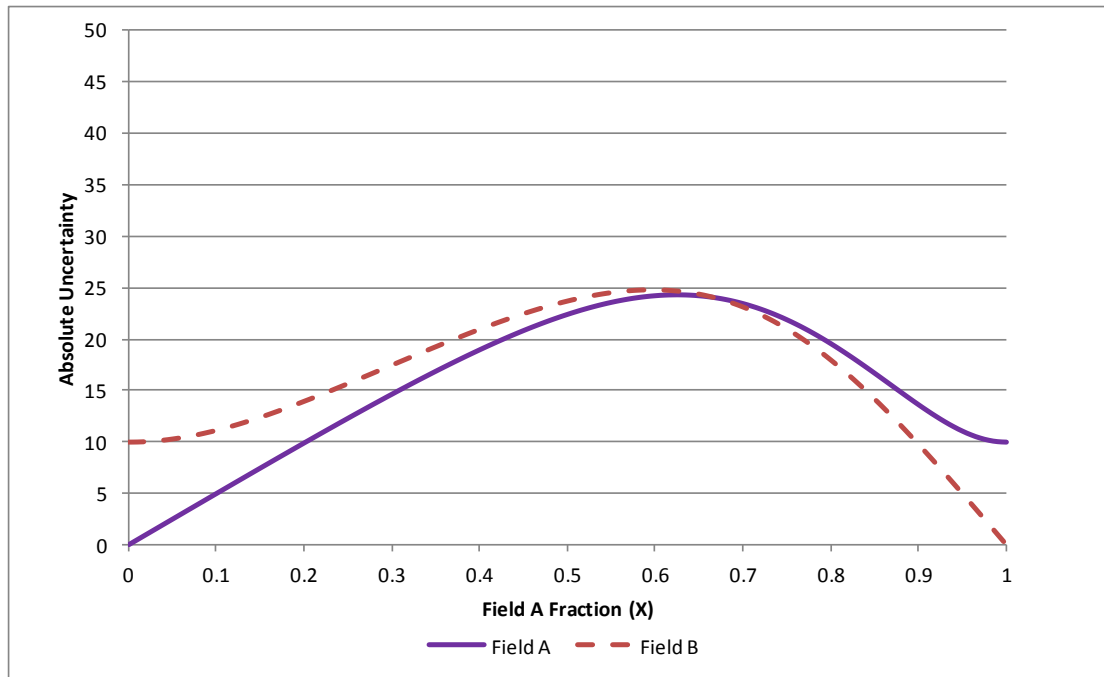

Figure 14 – UBA Absolute Uncertainty

Comparison with the analogous figures for the Pro Rata and By Difference uncertainty plots illustrate that the UBA method generally produces lower allocation uncertainties for both Fields across the full range of relative flows.

However, at first sight this might not appear a fair comparison as it appears that the uncertainty in the uncertainties themselves (ϵ_A , ϵ_B and ϵ_M) in the UBA equation has not been accounted for. However, perhaps surprisingly, the sensitivity coefficients for these terms are almost zero and the allocation uncertainties are basically unaffected by the uncertainty in the uncertainties. This is demonstrated mathematically in Section 8.4 of the Appendix and has also been proven using Monte Carlo simulation.

Using the data in the above example, the allocation uncertainties for all three methods of allocation are compared in Figure 15 for Field A and Figure 16 for Field B:

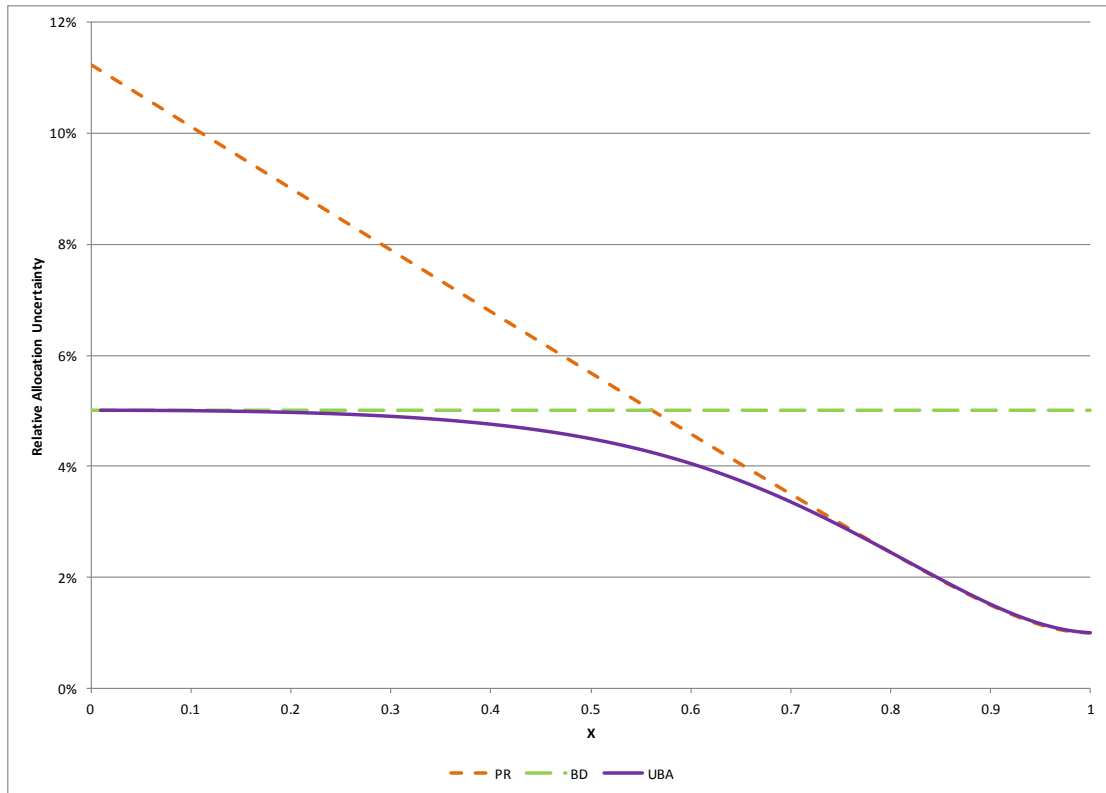

Figure 15 – Comparison of Relative Allocation Uncertainties for Field A

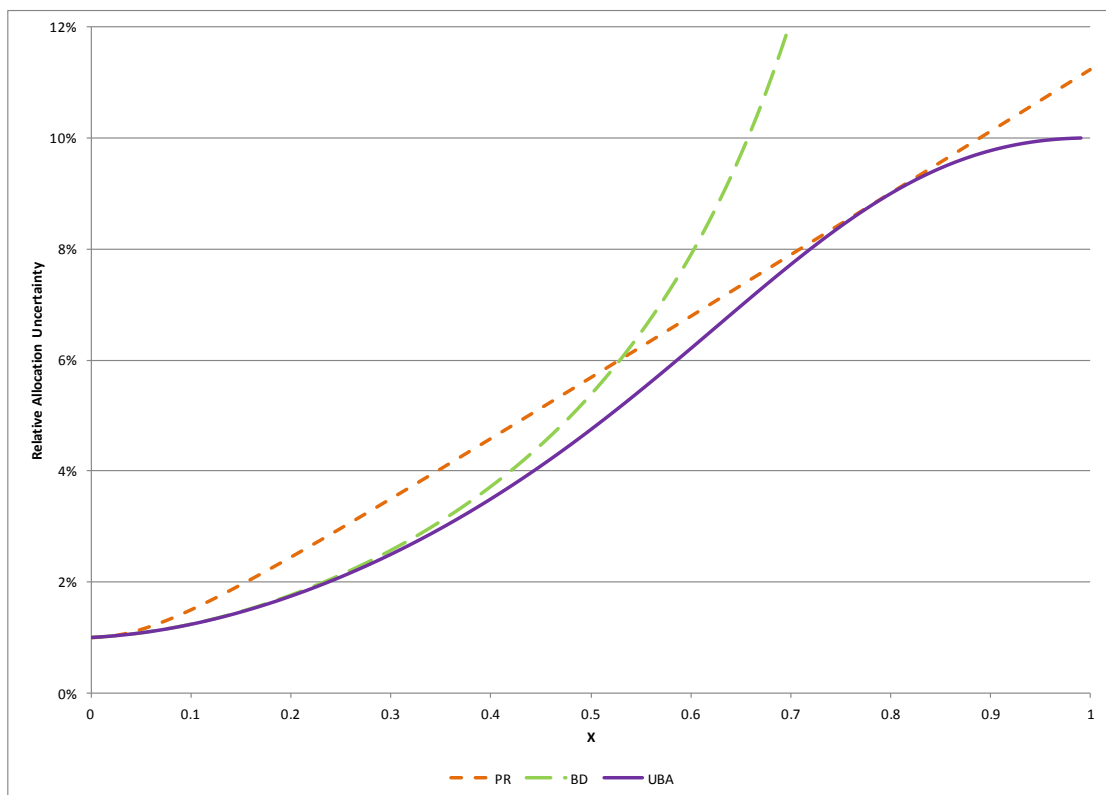

Figure 16 – Comparison of Relative Allocation Uncertainties for Field B

As can be observed the Uncertainty Based allocation produces allocation uncertainties that are for practical purposes better than or equal to those for either of the other methods for both fields.

In order to provide more of an overview of the uncertainty a three dimensional plot of Field A's relative allocation uncertainty for all three methods is presented in Figure 17:

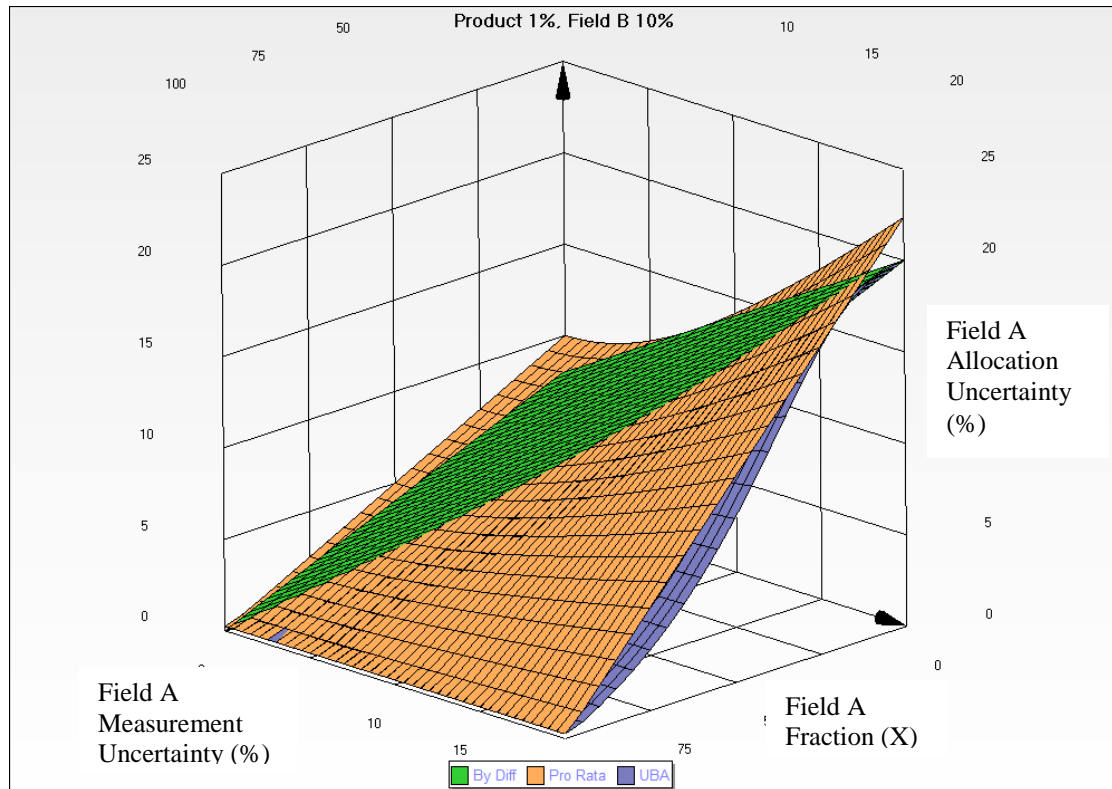

Figure 17 – Comparison of Relative Uncertainties for Field A – 3D Surface Plot

The height of the surfaces represents Field A's relative allocation uncertainty plotted against the vertical axis (AA Uncertainty (%)). The fraction Field A comprises (X) is plotted on the horizontal axis right to left, and the uncertainty in Field A's measurement, $\epsilon_{P,A}$, (from 0% to 20%) is plotted on the horizontal axis left to right.

Similarly for Field B:

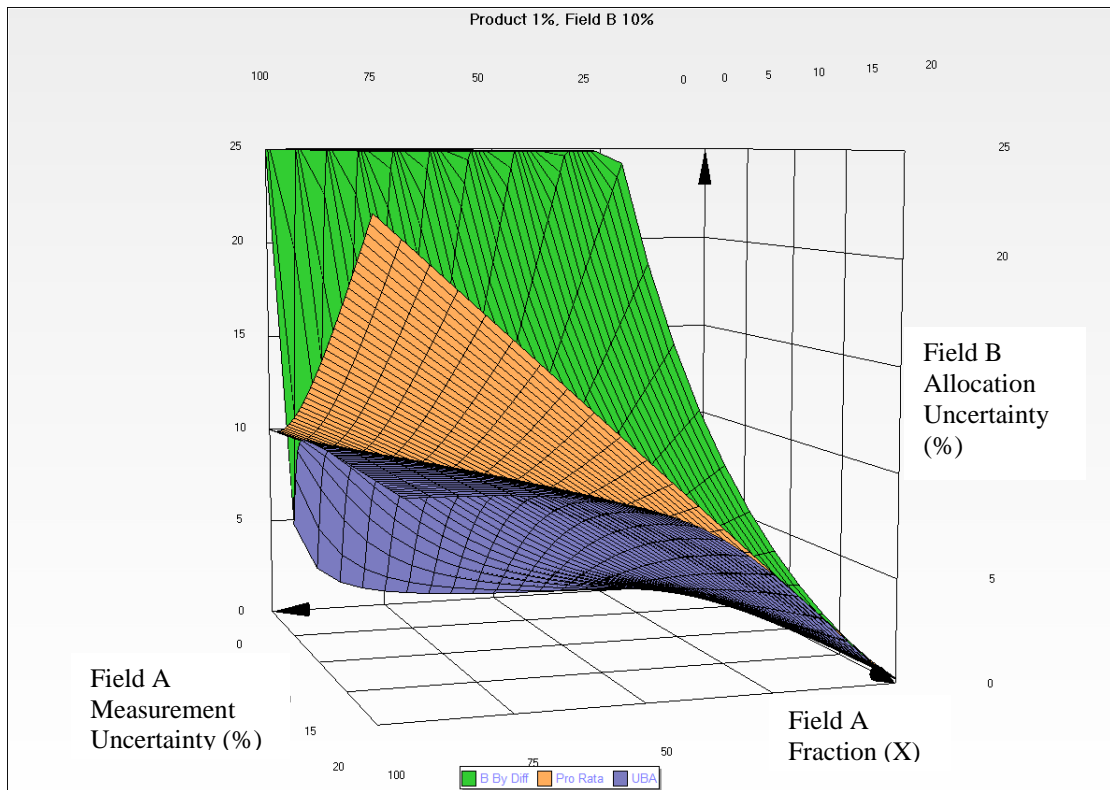

Figure 18 – Comparison of Relative Uncertainties for Field A – 3D Surface Plot

5 CONCLUSIONS

The following conclusions are expressed as a series of guidelines for the calculation of allocation uncertainties. These are not intended to be definitive but are borne out of the authors' experience in calculating allocation uncertainties for a range of systems and applications.

- Use analytical (TSM) and Monte Carlo (MCM) methods to cross check against each other when calculating allocation uncertainties.
- Identify any terms in an allocation equation which are dependent on one another particularly when utilising the results of one allocation step in a subsequent step.
- When calculating the uncertainty, ensure that allocation equations are re-expressed in terms of independent terms, preferably inputs to the allocation system.
- Dependencies may not be explicit in the allocation equations themselves, for example the requirement for a composition to sum to 100% means that component mass (and molar) fractions are covariant, and this must be account for when calculating uncertainties.
- The covariance in mass (or molar) fractions can be accounted for by re-expressing the relevant equation with the sum of the component fractions on the denominator.
- For MPFMs it cannot be assumed that a constant relative uncertainty applies for the individual oil and water phase flow rates across a range of water cuts.

- When calculating allocation uncertainties it is important to determine both relative and absolute uncertainties. For example, with MPFMs, high relative uncertainties in oil phase flow rates can be encountered at high water cuts - this is not necessarily a problem if the associated absolute uncertainty is low.
- Use the analytical method when comparing uncertainties associated with different allocation approaches, (Pro Rata, By Difference, UBA). The analytical approach allows a complete picture of the comparative allocation uncertainties over the full range of flows and measurement uncertainties to be generated. This in turn allows the exposure to over- or under allocation to be assessed in any cost benefit analysis which may influence measurement equipment and allocation scheme selection.

6 NOTATION AND ABBREVIATIONS

a,b,c	Exponent or power	R	Gas constant
A	Allocated quantity or Field A identifier	S	Process factor
B	Field B identifier	T	Temperature or total identifier
c	Component identifier	TSM	Taylor Series Method
D	Diameter	UBA	Uncertainty Based Allocation
e	Absolute uncertainty	U	Absolute uncertainty
G	Condensate quantity or flow or identifier	V	Volume
G	Gas quantity or flow or identifier	Wat	Water phase identifier
GUM	Guide to Uncertainty in Measurement [1]	WLR	Water liquid ratio
i	Component or input identifier	x	Fractional flow of Field A
j	Component identifier	x_i	Input variable, i
k	Constant	X	Mass fraction or percent
L	Length	y	Result of an equation
Liq	Combined liquid phase(s) identifier	α	Field Alpha identifier
M	Commingled quantity or flow	β	Field Bravo identifier
MCM	Monte Carlo Method	Δ	Imbalance
MPFM	Multi-phase flow meter	ϵ	Relative uncertainty
Oil	Oil phase identifier	ρ	Molar density
N	Number of components	θ	Fractional absolute variance of Field A measurement
P	Pressure or production quantity	ψ	Fractional flow of Field A when Pro Rata and By Difference allocation uncertainties are equal
$r_{i,j}$	Correlation coefficient between components i and j		

7 REFERENCES

- [1] International Organization for Standardization, Guide to the Expression of Uncertainty in Measurement, ISO Geneva 1993. Corrected and reprinted 1995.
- [2] Joint Committee for Guides in Metrology (JCGM), "Evaluation of Measurement Data – Supplement 1 to the 'Guide to the Expression of Uncertainty in Measurement' – Propagation of Distributions Using and Monte Carlo Method" JCGM 101: 2008, France 2008.
- [3] Measurement of fluid flow — Procedures for the evaluation of uncertainties, BS, ISO 5168:2005.
- [4] Experimentation, Validation, and Uncertainty Analysis for Engineers, 3rd Edition, Hugh W. Coleman and W. Glenn Steele, 2009, ISBN 978-0-470-16888-2.
- [5] Use of Subsea Wet Gas Flowmeters in Allocation Measurement Systems, API RP 85, First Edition, August 2003.
- [6] Determination of Measurement Uncertainty for the Purpose of Wet Gas Hydrocarbon Allocation, R. A. Webb, W. Letton, M. Basil, North Sea Flow Measurement Workshop 2002.
- [7] Experiences in the Use of Uncertainty Based Allocation in a North Sea Offshore Oil Allocation System, P. Stockton and A. Spence, Production and Upstream Flow Measurement Workshop, 12-14 February 2008.

8 APPENDIX OF EQUATION DERIVATIONS

8.1 Specific Form of Uncertainty Equation for Multiples and Quotients

Consider an equation of the form:

$$y = k * x_1^a * x_2^b * x_3^c \quad (54)$$

Where y is calculated from a number of input variables x_1 , x_2 , etc. which may be raised to any power, a, b, etc and multiplied by a constant k. The powers can be negative representing quotient terms.

In order to calculate the uncertainty in y, the sensitivity coefficients are required for each of the input variables, and these are obtained from the first order partial differentials of y with respect to x_1 , x_2 , etc. For example:

$$\frac{\partial y}{\partial x_1} = a * k * x_1^{a-1} * x_2^b * x_3^c \quad (55)$$

And so on for x_2 , etc.

The square of the absolute uncertainty in y is given by:

$$Uy^2 = \left(\frac{\partial y}{\partial x_1}\right)^2 Ux_1^2 + \left(\frac{\partial y}{\partial x_2}\right)^2 Ux_2^2 + \left(\frac{\partial y}{\partial x_3}\right)^2 Ux_3^2 \quad (56)$$

Substituting for the sensitivity coefficients:

$$Uy^2 = (a * k * x_1^{a-1} * x_2^b * x_3^c)^2 Ux_1^2 + (b * k * x_1^a * x_2^{b-1} * x_3^c)^2 Ux_2^2 + (c * k * x_1^a * x_2^b * x_3^{c-1})^2 Ux_3^2 \quad (57)$$

Dividing through by y^2 and substituting Equation (54) on the right hand side:

$$\frac{Uy^2}{y^2} = \frac{(a * k * x_1^{a-1} * x_2^b * x_3^c)^2 Ux_1^2 + (b * k * x_1^a * x_2^{b-1} * x_3^c)^2 Ux_2^2 + (c * k * x_1^a * x_2^b * x_3^{c-1})^2 Ux_3^2}{(k * x_1^a * x_2^b * x_3^c)^2} \quad (58)$$

Which simplifies to:

$$\frac{Uy^2}{y^2} = \frac{a^2 * Ux_1^2}{x_1^2} + \frac{b^2 * Ux_2^2}{x_2^2} + \frac{c^2 * Ux_3^2}{x_3^2} \quad (59)$$

The left hand side of Equation (59) is equal to the square of the relative uncertainty of y and Ux_1/x_1 is the relative uncertainty in x_1 (ϵx_1), etc. Hence Equation (59) reduces to:

$$\epsilon y = \sqrt{a^2 * \epsilon x_1^2 + b^2 * \epsilon x_2^2 + c^2 * \epsilon x_3^2} \quad (60).$$

8.2 Pro Rata Field A

Allocated quantities employing the proportional method are given by:

$$A_A = M * \left(\frac{P_A}{P_A + P_B} \right) \quad (61)$$

and,

$$A_B = M * \left(\frac{P_B}{P_A + P_B} \right) \quad (62)$$

In order to calculate the uncertainty in A_A , the sensitivity coefficients are required:

$$\frac{\partial A_A}{\partial M} = \frac{P_A}{(P_A + P_B)} = x \quad (63)$$

$$\frac{\partial A_A}{\partial P_A} = M * \left[\left(\frac{1}{(P_A + P_B)} + \frac{-P_A}{(P_A + P_B)^2} \right) \right] = \frac{M * P_B}{(P_A + P_B)^2} \quad (64)$$

In an unbiased system, the expected value of M equals the sum of P_A and P_B , $E[M] = E[P_A + P_B]$. Hence Equation (64) simplified to:

$$\frac{\partial A_A}{\partial P_A} = \left(\frac{P_B}{(P_A + P_B)} \right) = (1 - x) \quad (65)$$

Similarly,

$$\frac{\partial A_A}{\partial P_B} = M * \left[\left(\frac{-P_A}{(P_A + P_B)^2} \right) \right] = -x \quad (66)$$

The absolute uncertainty in A_A is given by:

$$UA_A = \sqrt{x^2 UM^2 + (1-x)^2 UP_A^2 + (-x)^2 UP_B^2} \quad (67)$$

And relative uncertainty in A_A by:

$$\varepsilon_{A,A} = \sqrt{\varepsilon_M^2 + (1-x)^2 (\varepsilon_{P,A}^2 + \varepsilon_{P,B}^2)} \quad (68)$$

8.3 By Difference Field B

When employing the By Difference approach, the allocated quantities are given by:

$$A_A = P_A \quad (69)$$

for Field A and for Field B by difference,

$$A_B = M - P_A \quad (70)$$

In order to calculate the uncertainty in A_B , the sensitivity coefficients are required:

$$\frac{\partial A_B}{\partial M} = 1 \quad (71)$$

$$\frac{\partial A_B}{\partial P_A} = -1 \quad (72)$$

The absolute uncertainty in A_B is given by:

$$UA_B = \sqrt{1^2 UM^2 + (-1)^2 UP_A^2} \quad (73)$$

And relative uncertainty in A_B by:

$$\varepsilon_{A,B} = \frac{\sqrt{\varepsilon_M^2 + x^2 \varepsilon_{P,A}^2}}{(1-x)} \quad (74).$$

8.4 Uncertainty Based Allocation Field A

When employing the UBA approach, the allocated quantities are given by:

$$A_A = P_A + \theta * \Delta \quad (75)$$

$$A_B = P_B + (1-\theta) * \Delta \quad (76)$$

Where,

$$\Delta = M - P_A - P_B \quad (77)$$

And θ is:

$$\theta = \frac{e_A^2}{e_A^2 + e_B^2} = \frac{P_A^2 \varepsilon_A^2}{P_A^2 \varepsilon_A^2 + P_B^2 \varepsilon_B^2} \quad (78)$$

Substituting in (77) and (78) Equation (75):

$$A_A = P_A + \left(\frac{P_A^2 \varepsilon_A^2}{P_A^2 \varepsilon_A^2 + P_B^2 \varepsilon_B^2} \right) * (M - P_A - P_B) \quad (79)$$

In order to calculate the uncertainty in A_A , the sensitivity coefficients are required:

$$\frac{\partial A_A}{\partial M} = \theta \quad (80)$$

$$\frac{\partial A_A}{\partial P_A} = 1 + (-1) * \theta + (M - P_A - P_B) * \left(\frac{2P_A \varepsilon_A^2}{P_A^2 \varepsilon_A^2 + P_B^2 \varepsilon_B^2} + \frac{(-1) * 2 * P_A^3 \varepsilon_A^4}{(P_A^2 \varepsilon_A^2 + P_B^2 \varepsilon_B^2)^2} \right) \quad (81)$$

In an unbiased system, the expected value of M equals the sum of P_A and P_B , $E[M] = E[P_A + P_B]$ and hence $E[M - (P_A + P_B)] = 0$. Hence Equation (81) can be reduced to:

$$\frac{\partial A_A}{\partial P_A} = 1 - \theta \quad (82)$$

Similarly,

$$\frac{\partial A_A}{\partial P_B} = (-1) * \theta + (M - P_A - P_B) * \left(\frac{(-1) * 2 * P_A^2 \varepsilon_A^2 P_B \varepsilon_B^2}{(P_A^2 \varepsilon_A^2 + P_B^2 \varepsilon_B^2)^2} \right) \quad (83)$$

Since $E[M - (P_A + P_B)] = 0$,

$$\frac{\partial A_A}{\partial P_B} = -\theta \quad (84)$$

The measurement uncertainties are also inputs to the UBA equation and there will be uncertainties in the uncertainties, hence calculating the sensitivity coefficient with respect to ε_B :

$$\frac{\partial A_A}{\partial \varepsilon_B} = (M - P_A - P_B) * \left(\frac{(-1) * 2 * P_A^2 \varepsilon_A^2 P_B^2 \varepsilon_B}{(P_A^2 \varepsilon_A^2 + P_B^2 \varepsilon_B^2)^2} \right) \quad (85)$$

But since $E[M - (P_A + P_B)] = 0$,

$$\frac{\partial A_A}{\partial \varepsilon_B} = 0 \quad (86)$$

A similar result is obtained for the sensitivity coefficient with respect to ε_A . Surprisingly, this means the uncertainty in A_A is not sensitive to the uncertainties in ε_A and ε_B .

However, this is not completely true as the $E[M - (P_A + P_B)] = 0$ is not strictly the same as the expectation value of the whole right hand term:

$$E \left[(M - P_A - P_B) * \left(\frac{(-1) * 2 * P_A^2 \varepsilon_A^2 P_B^2 \varepsilon_B}{(P_A^2 \varepsilon_A^2 + P_B^2 \varepsilon_B^2)^2} \right) \right]$$

which strictly should be considered. However, for reasonable estimates of ε_A and ε_B , the above approximation holds and the absolute uncertainty in A_A is given by:

$$UA_A = \sqrt{\theta^2 UM^2 + \theta^2 UP_B^2 + (1-\theta)^2 UP_A^2} \quad (87)$$

The relative uncertainty in Field A's allocation is given by:

$$\varepsilon_{A,A} = \frac{\sqrt{\theta^2 \varepsilon_M^2 + x^2 (1-\theta)^2 \varepsilon_{P,A}^2 + \theta^2 (1-x)^2 \varepsilon_{P,B}^2}}{x} \quad (88)$$